

### Features:

- Isolated mounting base 2500V~
- Pressure contact technology with  
Increased power cycling capability
- Space and weight savings

### Typical Applications

- AC/DC Motor drives
- Various rectifiers
- DC supply for PWM inverter

$I_{T(AV)}$       **160A**  
 $V_{DRM}/V_{RRM}$     **600~1800V**  
 $I_{TSM}$              **$6.0A \times 10^3$**   
 $I^2t$                  **$180A^2 S \cdot 10^3$**



SYMBOL	CHARACTERISTIC	TEST CONDITIONS	T <sub>J</sub> (°C)	VALUE			UNIT
				Min	Type	Max	
$I_{T(AV)}$	Mean on-state current	180° half sine wave 50Hz Single side cooled, T <sub>c</sub> =85°C	125			160	A
$I_{T(RMS)}$	RMS on-state current		125			251	A
$V_{DRM}$ $V_{RRM}$	Repetitive peak off-state voltage Repetitive peak reverse voltage	$V_{DRM}$ & $V_{RRM}$ tp=10ms $V_{DSM}$ & $V_{RSM} = V_{DRM}$ & $V_{RRM} + 100V$ respectively	125	600		1800	V
$I_{DRM}$ $I_{RRM}$	Repetitive peak current	at $V_{DRM}$ at $V_{RRM}$	125			15	mA
$I_{TSM}$	Surge on-state current	10ms half sine wave	125			6.0	KA
$I^2t$	I <sup>2</sup> T for fusing coordination	V <sub>R</sub> =60%V <sub>RRM</sub>				180	A <sup>2</sup> s*10 <sup>3</sup>
$V_{TO}$	Threshold voltage		125			0.8	V
$r_T$	On-state slop resistance					1.69	mΩ
$V_{TM}$	Peak on-state voltage	I <sub>TM</sub> =480A	25			1.70	V
dv/dt	Critical rate of rise of off-state voltage	V <sub>DM</sub> =67%V <sub>DRM</sub>	125			800	V/μs
di/dt	Critical rate of rise of on-state current	Gate source 1.5A t <sub>r</sub> ≤0.5μs Repetitive	125			100	A/μs
$I_{GT}$	Gate trigger current		25	30		150	mA
$V_{GT}$	Gate trigger voltage	V <sub>A</sub> =12V, I <sub>A</sub> =1A		1.0		2.5	V
$I_H$	Holding current			20		150	mA
$V_{GD}$	Non-trigger gate voltage	V <sub>DM</sub> =67%V <sub>DRM</sub>	125	0.2			V
$R_{th(j-c)}$	Thermal resistance Junction to case	Single side cooled				0.170	°C/W
$R_{th(c-h)}$	Thermal resistance case to heatsink	Single side cooled				0.08	°C/W
$V_{iso}$	Isolation voltage	50Hz, R.M.S, t=1min, I <sub>iso</sub> :1mA(MAX)		2500			V
$F_m$	Thermal connection torque(M5)				4.0		N·m
	Mounting torque(M6)				6.0		N·m
$T_{stg}$	Stored temperature			-40		125	°C
$W_t$	Weight				320		g
Outline	214F3/216F3						

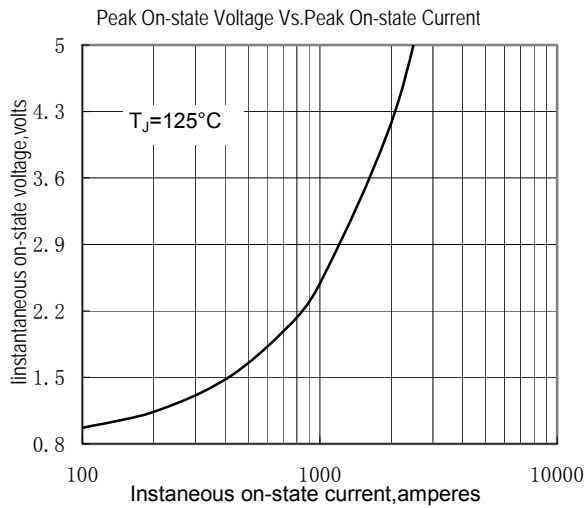

Fig.1

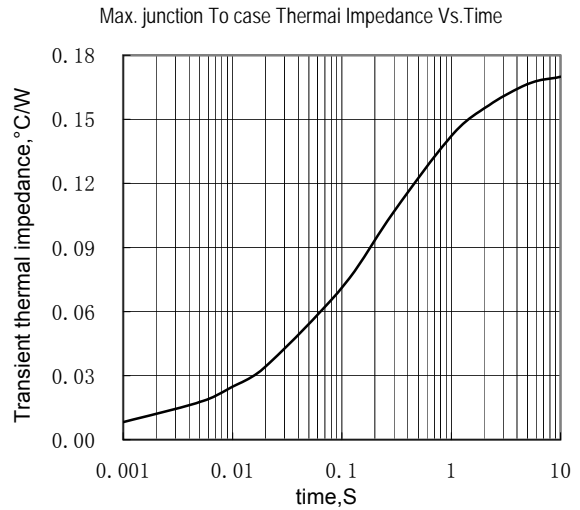

Fig.2

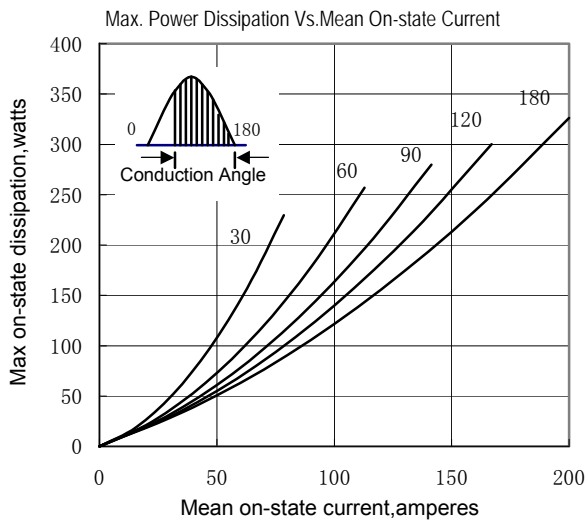

Fig.3

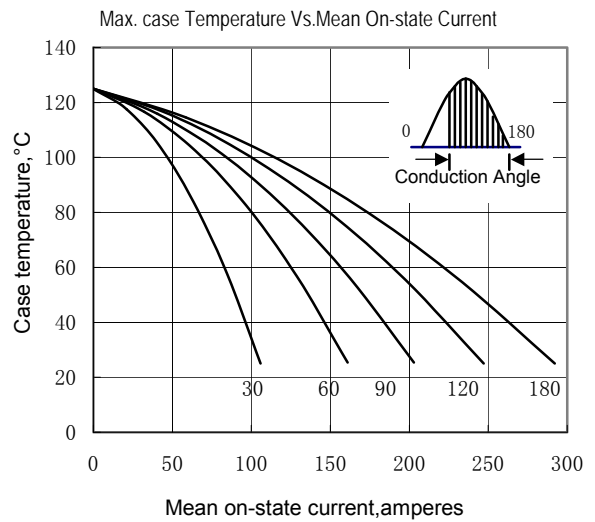

Fig.4

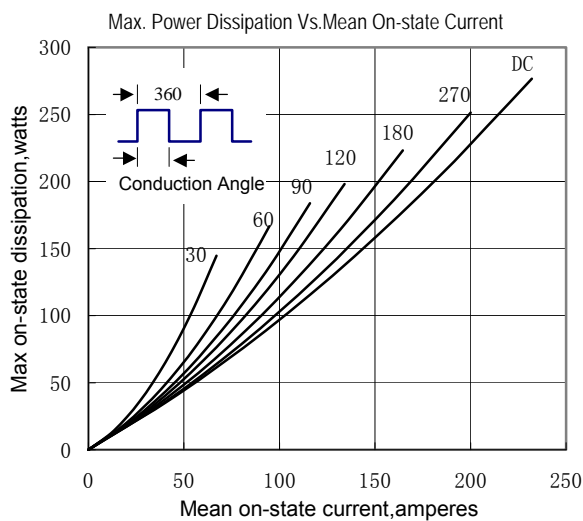

Fig.5

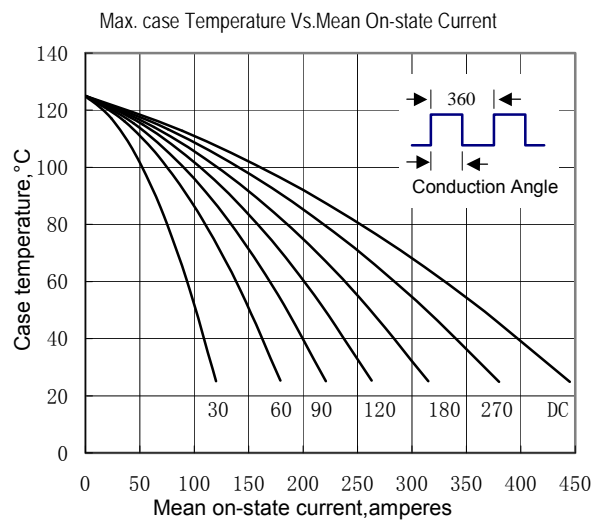

Fig.6

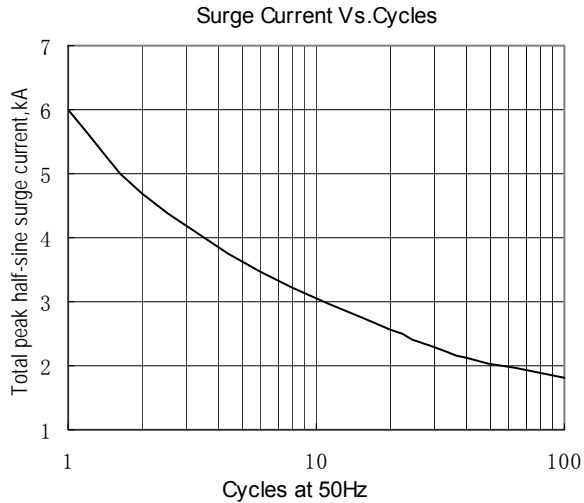

Fig.7

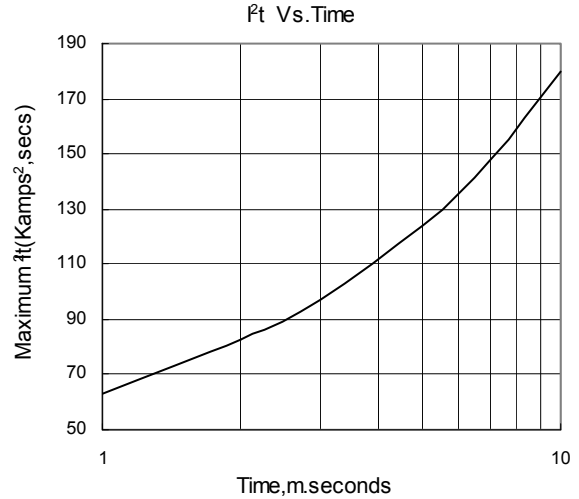

Fig.8

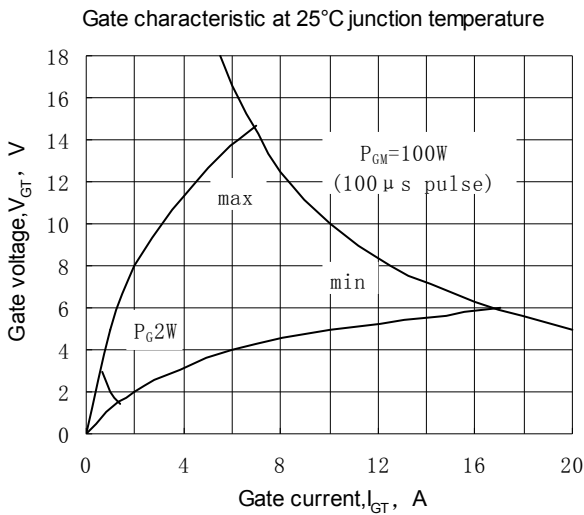

Fig.9

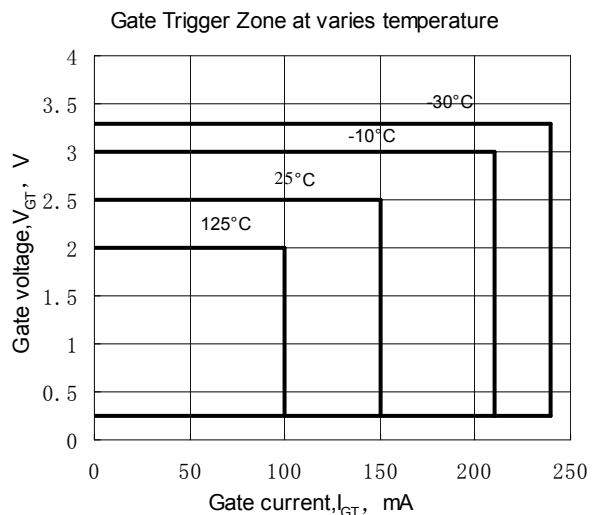
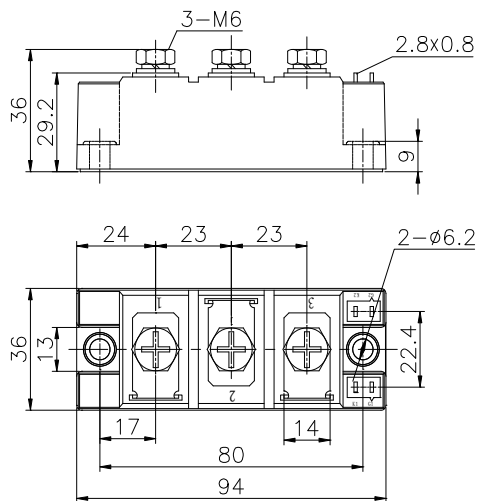

Fig.10

**Outline:**



214F3

