

**Features**

- Low forward voltage drop
- High reverse voltage
- Hermetic metal cases with ceramic insulators

Typical Applications

- All purpose high power rectifier diodes
- High power resistance welding equipment
- Non-controllable and half-controllable rectifiers
- Controlled rectifiers

Part No. Y100ZPC-ZT100cT

I_{F(AV)}	8000A	
V_{RRM}	1200V	1400V
	1600V	1800V
	2000V	

SYMBOL	CHARACTERISTIC	TEST CONDITIONS		T _j (°C)	VALUE			UNIT
					Min	Type	Max	
I _{F(AV)}	Mean forward current	180° half sine wave 50Hz Double side cooled,	T _C =85°C	175			8000	A
V _{RRM}	Repetitive peak reverse voltage	tp=10ms		175	1100		2000	V
I _{RRM}	Repetitive peak current	at V _{RRM}		175			250	mA
I _{FSM}	Surge forward current	10ms half sine wave		175			94	kA
I ² t	I ² t for fusing coordination	V _R =0.6V _{RRM}					44180	A ² s*10 ³
V _{FO}	Threshold voltage			175			0.85	V
r _F	Forward slope resistance						0.071	mΩ
V _{FM}	Peak forward voltage	I _{FM} =6000A, F=90kN		25			2.0	V
Q _{rr}	Recovery charge	I _{FM} =2000A, tp=4000μs, di/dt=-20A/μs, V _R =100V		175		6500		μC
R _{th(j-c)}	Thermal resistance Junction to case	At 180° sine double side cooled Clamping force 90kN					0.005	°C /W
R _{th(c-h)}	Thermal resistance case to heat sink					0.0015		
F _m	Mounting force				81		108	kN
T _{vj}	Junction temperature				-40		175	°C
T _{stg}	Stored temperature				-40		175	°C
W _t	Weight					2000		g
Outline	ZT100cT							

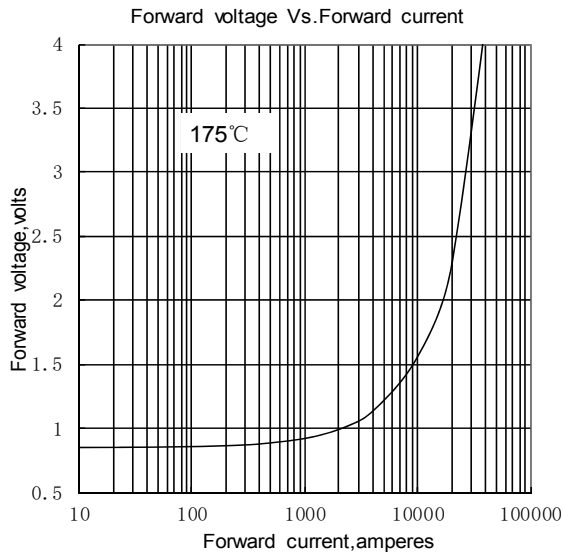

Fig.1

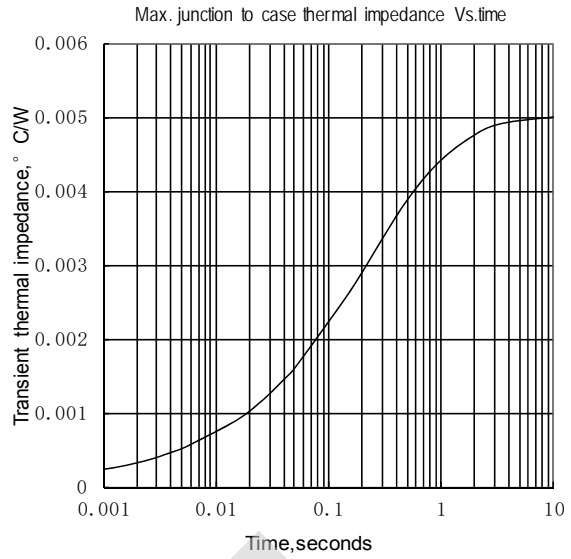

Fig.2

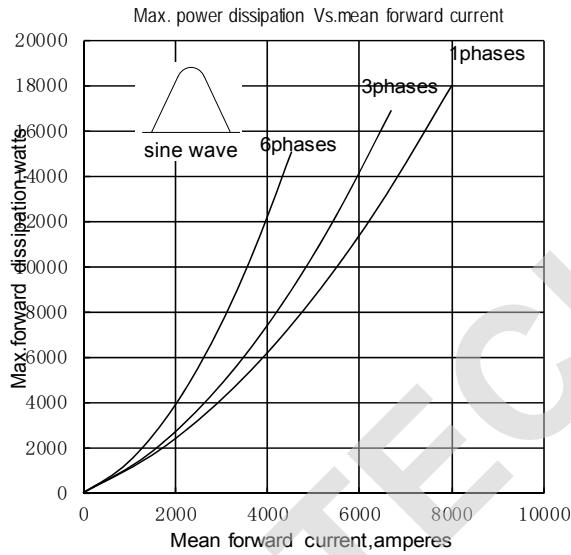

Fig.3

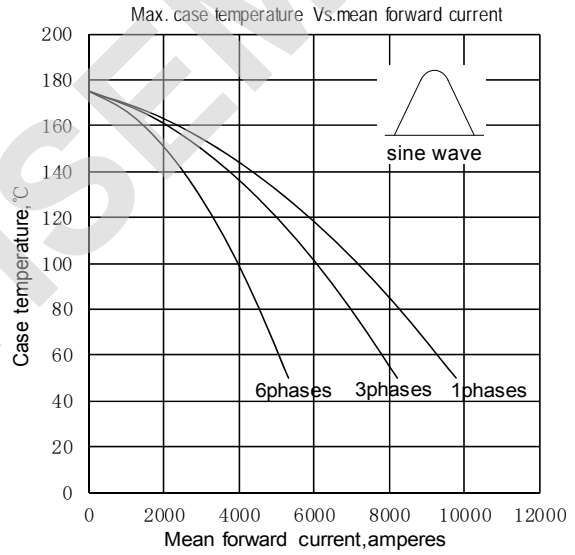

Fig.4

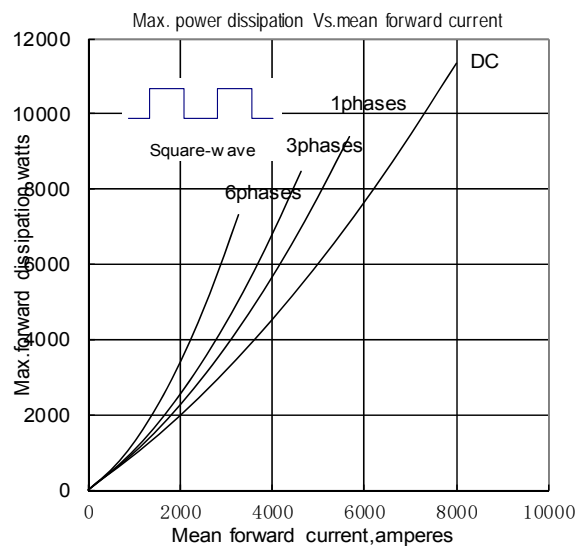

Fig.5

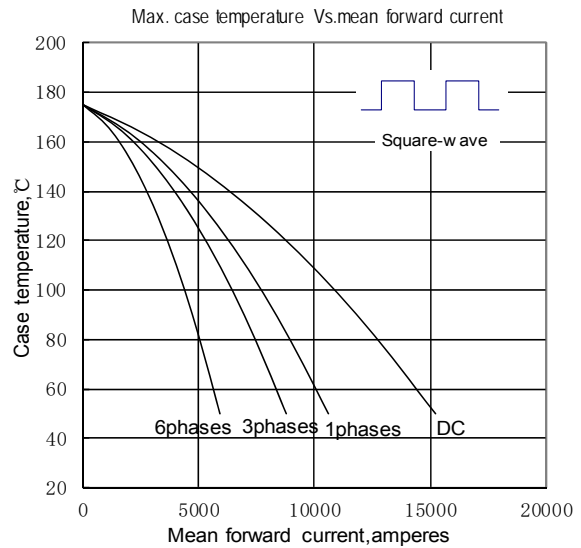

Fig.6

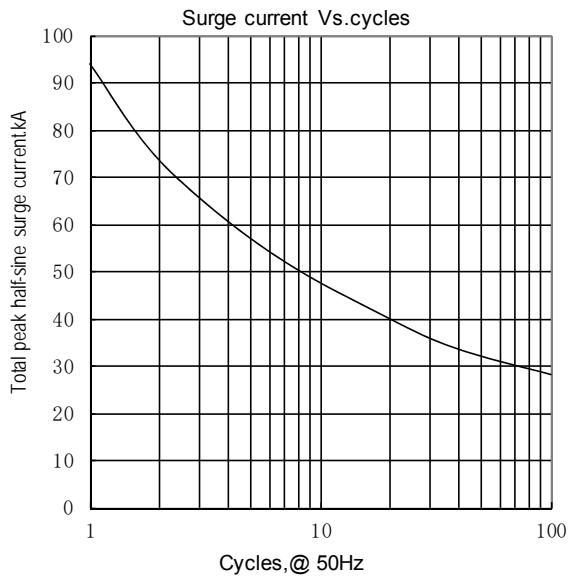

Fig.7

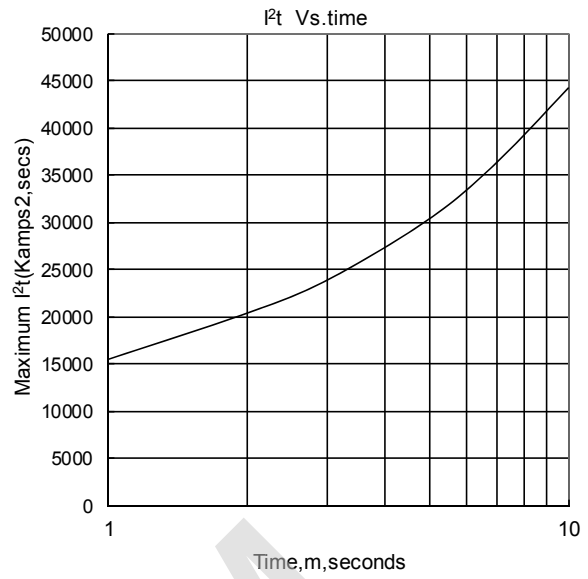
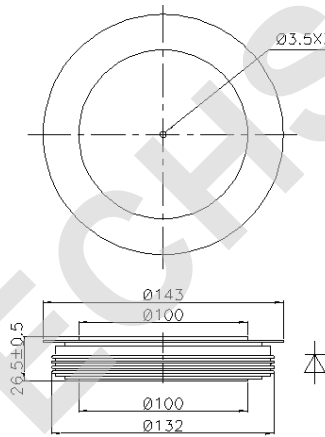

Fig.8

Outline:



TECHSEM reserves the right to change specifications without notice.