**Features**

- n Center amplifying gate
- n Metal case with ceramic insulator
- n Low on-state and switching losses

Typical Applications

- n AC controllers
- n DC and AC motor control
- n Controlled rectifiers

Part No. H100KPH-KT100cT

$I_{T(AV)}$	5290A
V_{DRM}, V_{RRM}	2200V 2500V
	2800V 3000V

SYMBOL	CHARACTERISTIC	TEST CONDITIONS	$T_j(^{\circ}C)$	VALUE			UNIT
				Min	Type	Max	
$I_{T(AV)}$	Mean on-state current	180° half sine wave 50Hz Double side cooled, $T_C=70^{\circ}C$	125			5290	A
V_{DRM} V_{RRM}	Repetitive peak off-state voltage Repetitive peak reverse voltage	$t_p=10ms$	125	2200		3000	V
I_{DRM} I_{RRM}	Repetitive peak current	at V_{DRM} at V_{RRM}	125			400	mA
I_{TSM}	Surge on-state current	10ms half sine wave $V_R=0.6V_{RRM}$	125			80	kA
I^2t	I^2t for fusing coordination					32000	$10^3 A^2s$
V_{TO}	Threshold voltage		125			0.83	V
r_T	On-state slope resistance					0.076	m Ω
V_{TM}	Peak on-state voltage	$I_{TM}=3000A, F=70kN$	25			1.15	V
dv/dt	Critical rate of rise of off-state voltage	$V_{DM}=0.67V_{DRM}$	125			2000	V/ μs
di/dt	Critical rate of rise of on-state current	$V_{DM}=67\%V_{DRM}$ Gate pulse $t_r \leq 0.5\mu s$ $I_{GM}=1.5A$	125			200	A/ μs
Q_{rr}	Recovery charge	$I_{TM}=2000A, t_p=4000\mu s, di/dt=-5A/\mu s,$ $V_R=100V$	125		4000		μC
I_{GT}	Gate trigger current	$V_A=12V, I_A=1A$	25	40		300	mA
V_{GT}	Gate trigger voltage			0.8		3.0	V
I_H	Holding current			25		200	mA
I_L	Latching current					1000	mA
V_{GD}	Non-trigger gate voltage	$V_{DM}=67\%V_{DRM}$	125			0.3	V
$R_{th(j-c)}$	Thermal resistance Junction to case	At 180° sine, double side cooled Clamping force 90.0kN				0.0057	$^{\circ}C/W$
$R_{th(c-hs)}$	Thermal resistance case to heatsink					0.0015	$^{\circ}C/W$
F_m	Mounting force			81		108	kN
T_{vj}	Junction temperature			-40		125	$^{\circ}C$
T_{stg}	Stored temperature			-40		140	$^{\circ}C$
W_t	Weight				1880		g
Outline	KT100cT						

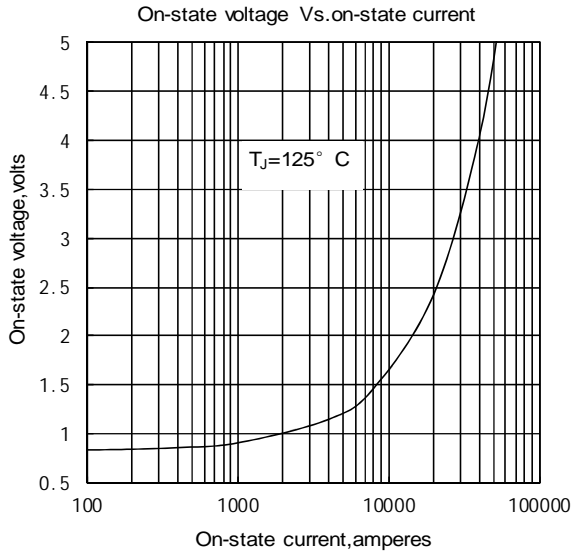

Fig.1

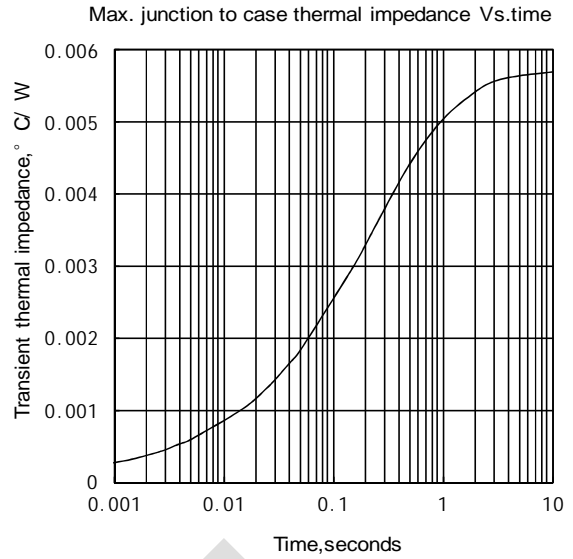

Fig.2

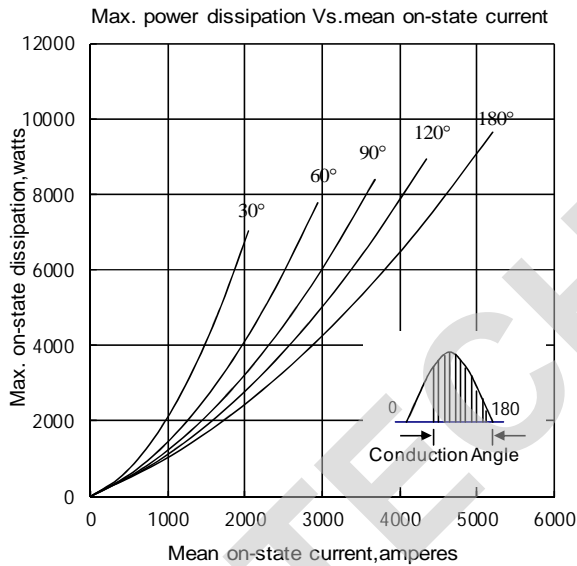

Fig.3

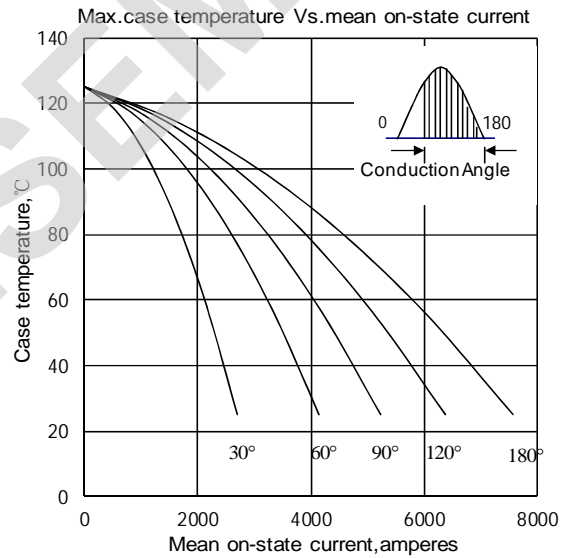

Fig.4

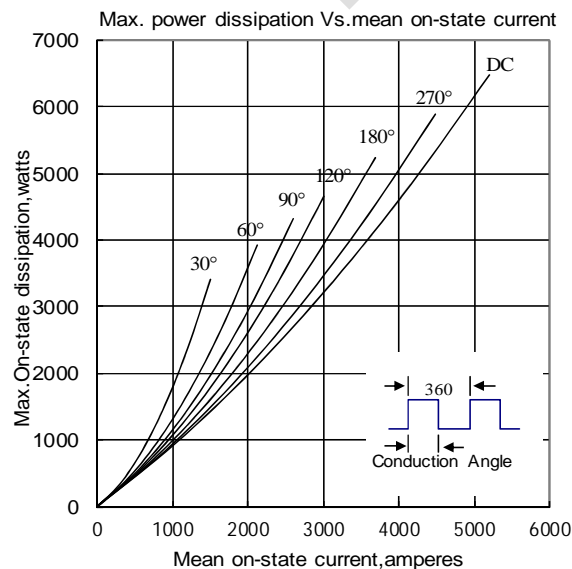

Fig.5

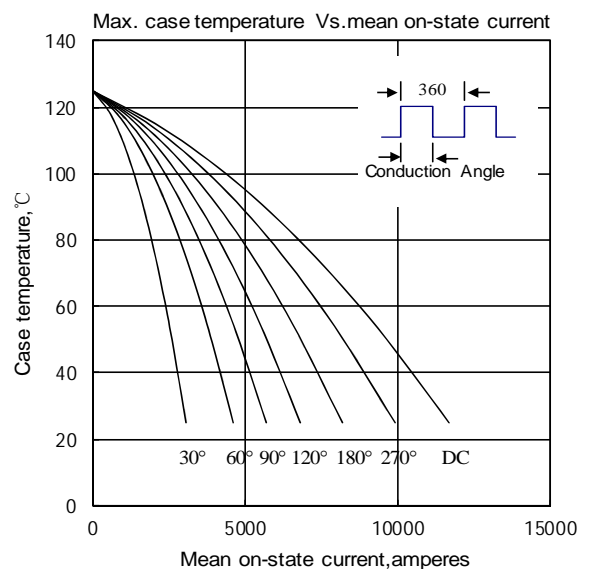

Fig.6

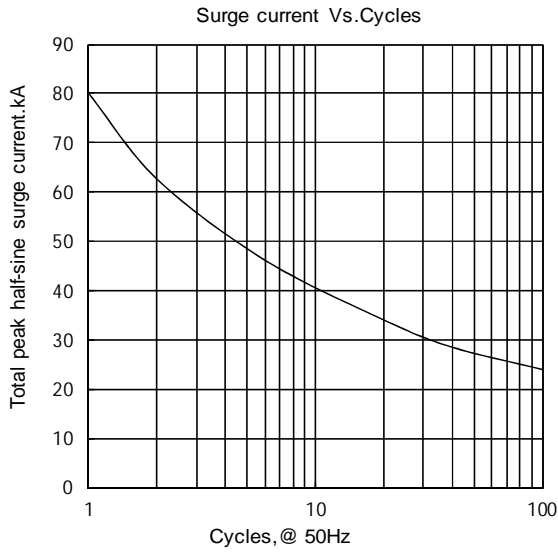

Fig.7

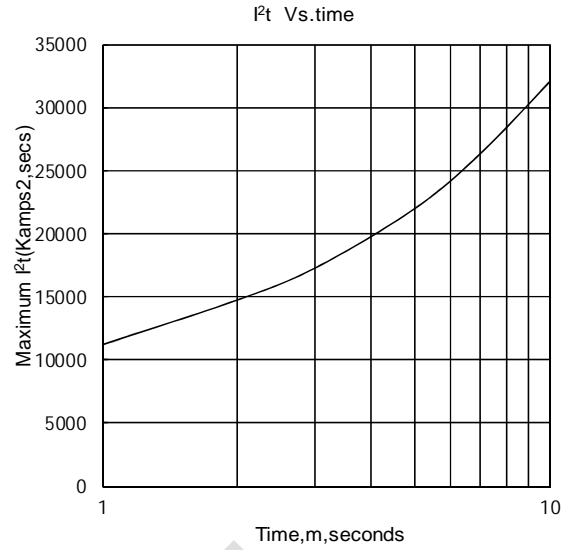

Fig.8

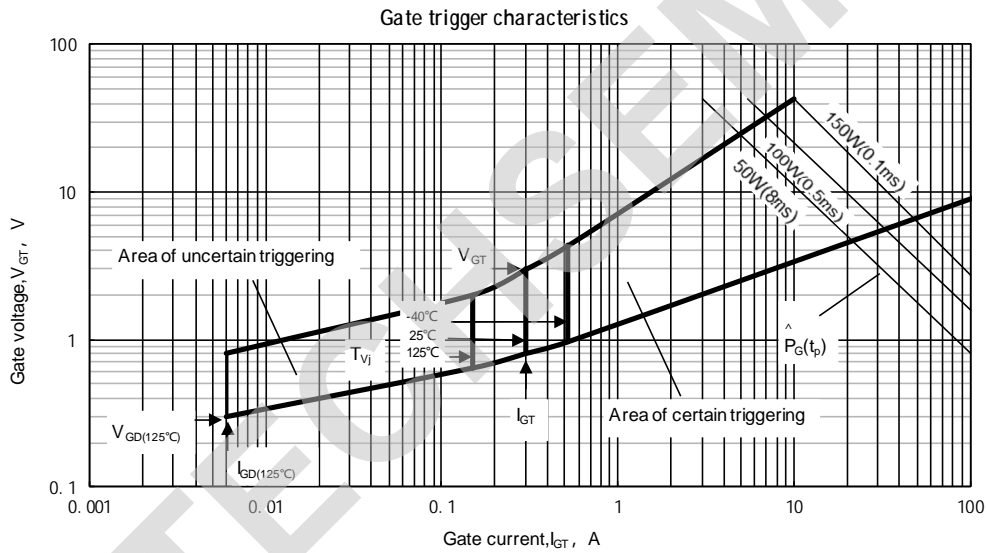
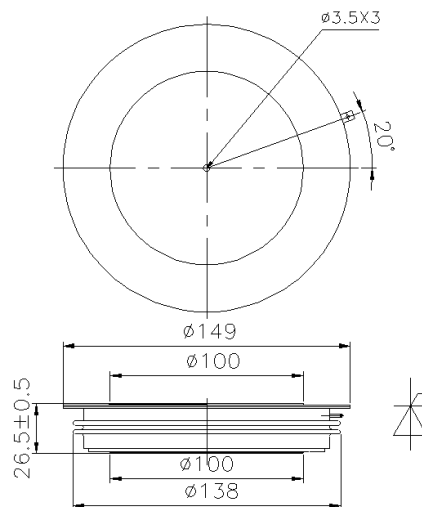

Fig.9

Outline:



TECHSEM reserves the right to change specifications without notice.