

Features

- n Interdigitated amplifying gates
- n Fast turn-on and high di/dt
- n Low switching losses

Typical Applications

- n Inductive heating
- n Electronic welders
- n Self-commutated inverters

Part No. Y60KKE-KT54cT

I_{T(AV)}	1750A
V_{DRM}, V_{RRM}	800V 1000V
	1200V 1400V
	1600V 1800V
t_q	18~50μs

SYMBOL	CHARACTERISTIC	TEST CONDITIONS	T _i (°C)	VALUE			UNIT
				Min	Type	Max	
I _{T(AV)}	Mean on-state current	180° half sine wave 50Hz Double side cooled, T _C =55°C	125			1750	A
V _{DRM} V _{RRM}	Repetitive peak off-state voltage Repetitive peak reverse voltage	tp=10ms	125	800		1800	V
I _{DRM} I _{RRM}	Repetitive peak current	at V _{DRM} at V _{RRM}	125			120	mA
I _{TSM}	Surge on-state current	10ms half sine wave	125			18	kA
I ² t	I ² t for fusing coordination	V _R =0.6V _{RRM}				1620	A ² s*10 ³
V _{TO}	Threshold voltage		125			1.48	V
r _T	On-state slope resistance					0.28	mΩ
V _{TM}	Peak on-state voltage	I _{TM} =3000A, F=28kN	25			3.15	V
dv/dt	Critical rate of rise of off-state voltage	V _{DM} =0.67V _{DRM}	125			1000	V/μs
di/dt	Critical rate of rise of on-state current	V _{DM} = 67%V _{DRM} to 2500A, Gate pulse t _r ≤0.5μs I _{GM} =1.5A Single pulse	125			1200	A/μs
Q _{rr}	Recovery charge	I _{TM} =1000A, tp=4000μs, di/dt=-20A/μs, V _R =100V	125		800		μC
t _q	Circuit commutated turn-off time	I _{TM} =1000A, tp=4000μs, V _R =100V dv/dt=30V/μs , di/dt=-20A/μs	125	18		50	μs
I _{GT}	Gate trigger current	V _A =12V, I _A =1A	25	40		300	mA
V _{GT}	Gate trigger voltage			0.9		3.5	V
I _H	Holding current			20		500	mA
I _L	Latching current					1000	mA
V _{GD}	Non-trigger gate voltage	V _{DM} =67%V _{DRM}	125			0.3	V
R _{th(j-c)}	Thermal resistance Junction to case	At 180° sine double side cooled Clamping force 28kN				0.016	°C /W
R _{th(c-h)}	Thermal resistance case to heat sink					0.004	
F _m	Mounting force			21		30	kN
T _{vj}	Junction temperature			-40		125	°C
T _{stg}	Stored temperature			-40		140	°C
W _i	Weight				650		g
Outline	KT54cT						

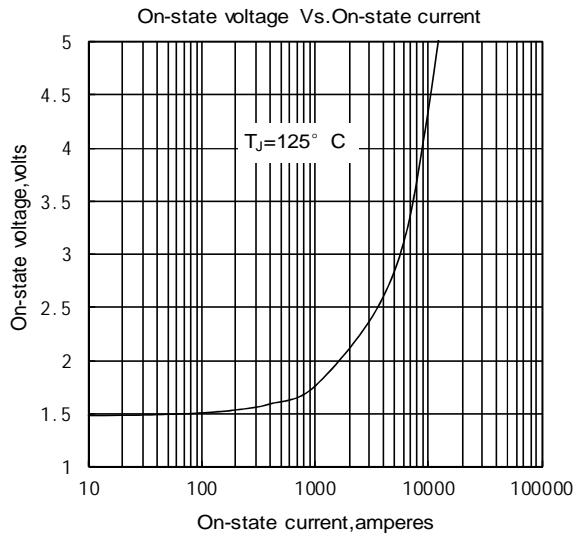

Fig. 1

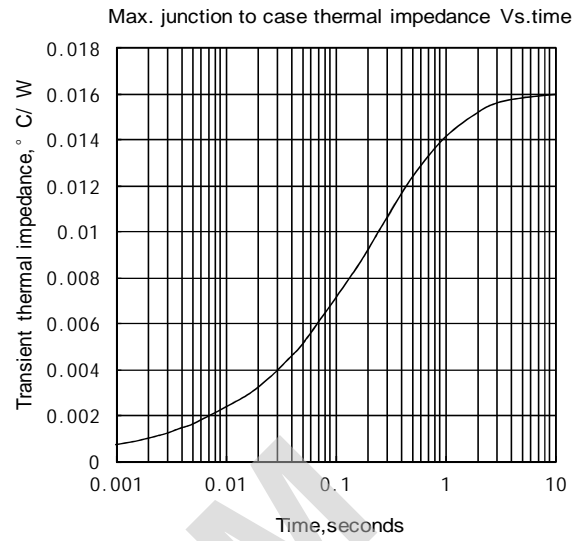

Fig. 2

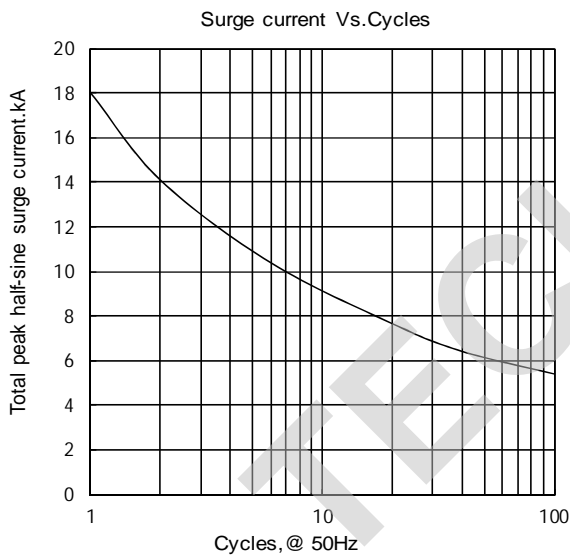

Fig. 3

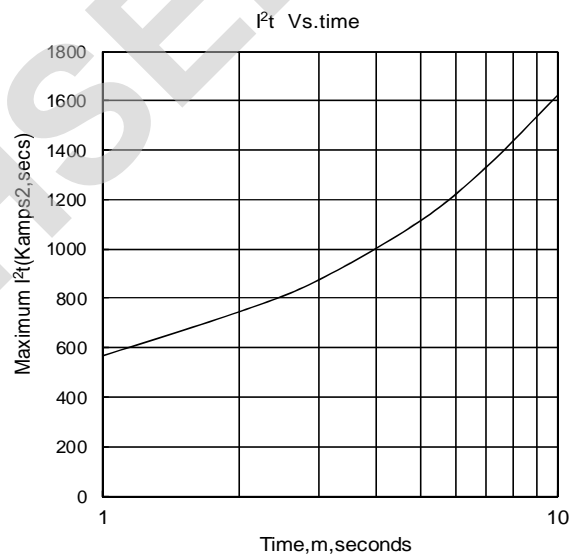
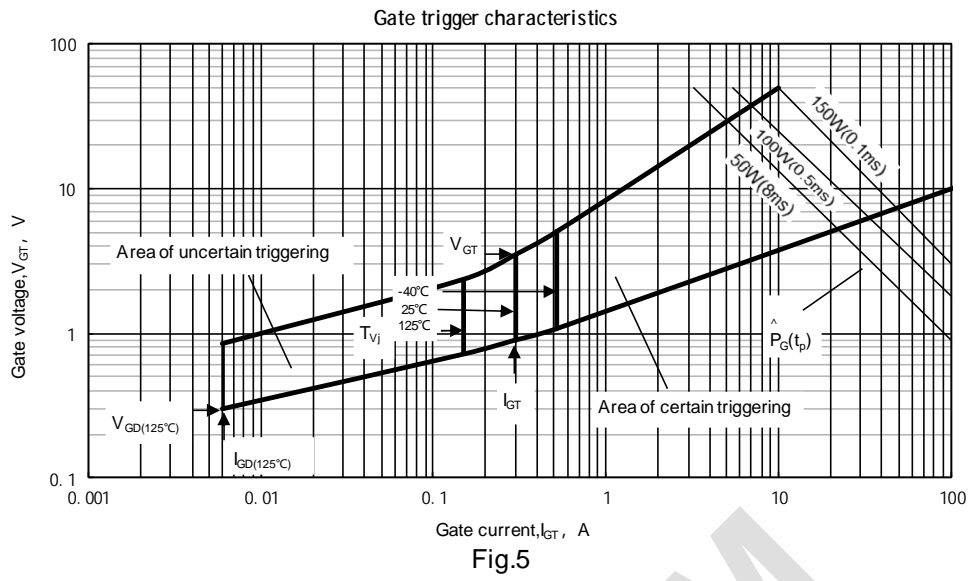
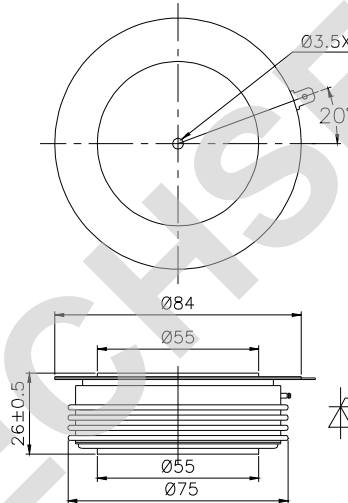

Fig. 4



Outline:



TECHSEM reserves the right to change specifications without notice.